

# SUMNER

## Material Lifts



Catalog 911

# Roust-A-Bout

*The versatile lift that makes one man a crew!*

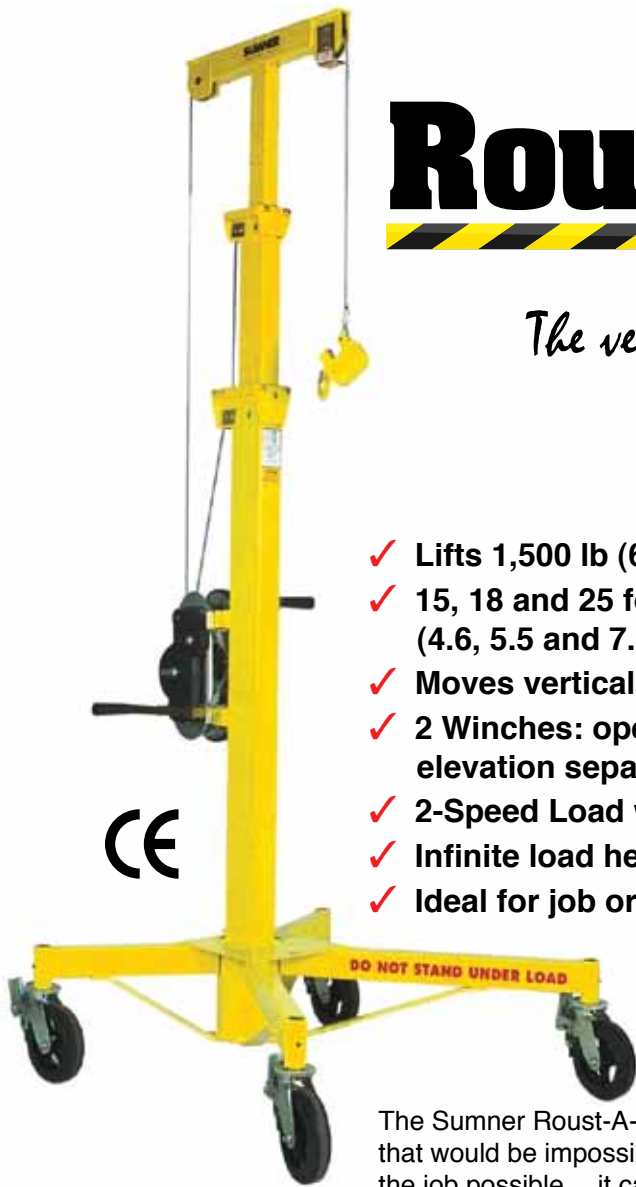

- ✓ Lifts 1,500 lb (680 Kg)
- ✓ 15, 18 and 25 foot heights (4.6, 5.5 and 7.6 m)
- ✓ Moves vertically and horizontally
- ✓ 2 Winches: operate load and mast elevation separately
- ✓ 2-Speed Load winches
- ✓ Infinite load height adjustment
- ✓ Ideal for job or shop

The Sumner Roust-A-Bout enables one man to lift and place loads in tight locations that would be impossible with other lifts. The flexible Roust-A-Bout not only makes the job possible... it can pay for itself in days by reducing job time!

This dependable lift can raise a 1,500 lb (680 kg) load up to 25 feet in minutes. In addition, large 8" (20.3 cm) casters permit a fully loaded Roust-A-Bout to position pipe or beams with ease.

Wider loads up to 1,000 lb (455 Kg) can be handled with the addition of Sumner's Tee Head Extension Bar.

The Roust-A-Bout eliminates the need for come alongs, scaffolds, monorails and swing booms.

Mast and base sections separate quickly for ease of transportation and storage.

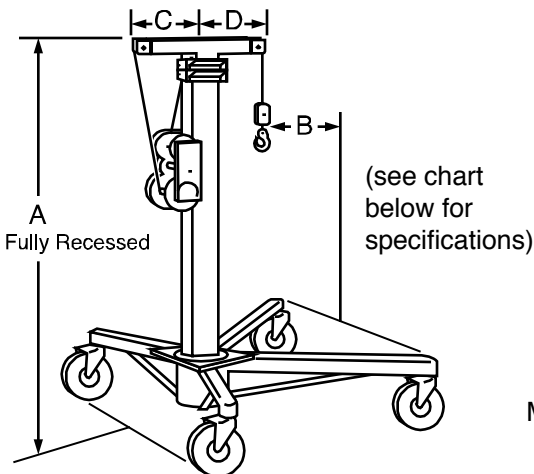

Part No.	Description	Weight		A		B		C/D		Base		Max Height	
		lbs	kg	inch	cm	inch	cm	inch	cm	inch	cm	feet	meters
780300	R-100 Roust-A-Bout 15' Top Height	311	140	79	200	20	50	12	30	32 x 40	80 x 100	15	4.6
780301	R-150 Roust-A-Bout 15' Top Height	311	140	79	200	20	50	12	30	40 x 40	100 x 100	15	4.6
780302	R-180 Roust-A-Bout 18' Top Height	337	153	126	320	25	63	14.5	36	50 x 50	125 x 125	18	5.5
780303	R-250 Roust-A-Bout 25' Top Height	381	170	119	302	30	75	17.5	44	60 x 60	150 x 150	25	7.6

# SUMNER

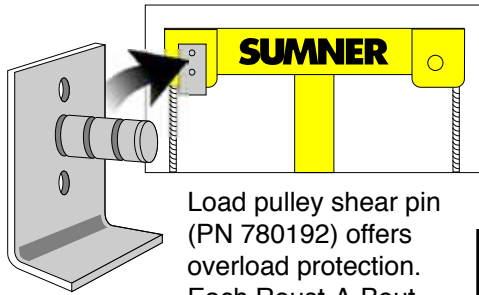

Load pulley shear pin (PN 780192) offers overload protection. Each Roust-A-Bout comes with a spare for quick, in-field resetting.

## Two Winch System

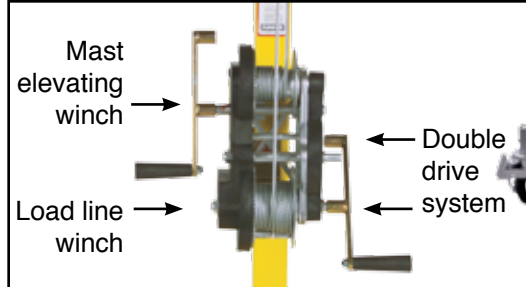

Now available in optional galvanized finish!



## The Roust-A-Bout tackles the tough jobs:

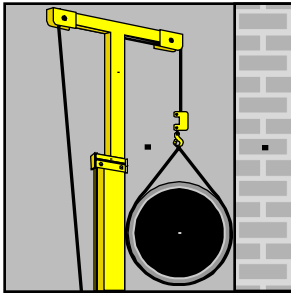

The Roust-A-Bout operates in tight areas that are inaccessible for other lifts.

Used in combination with Sumner's Adjust-A-Fit, the Roust-A-Bout can maneuver awkward objects for easy placement.

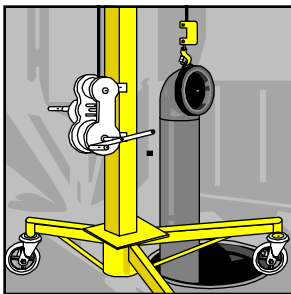
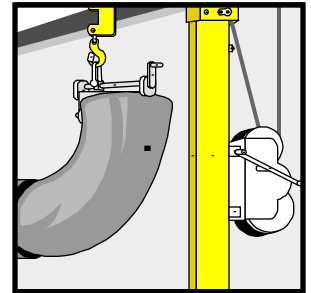

Loads can be lowered below floor level with the Roust-A-Bout's unique design.

One man can position objects weighing 1,500 lb (680 Kg) with infinite accuracy... up to 25 feet above!

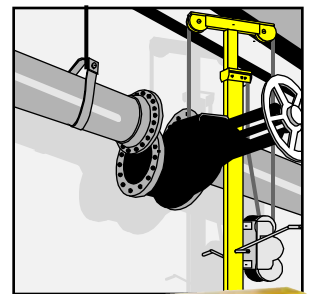

## Tee-Head Extension Bar

Lift wider loads with the Sumner Roust-A-Bout!



- ✓ Expands the Roust-A-Bout for handling bulky loads up to 1,000 lbs (455 kg)
- ✓ Takes only minutes to attach or detach

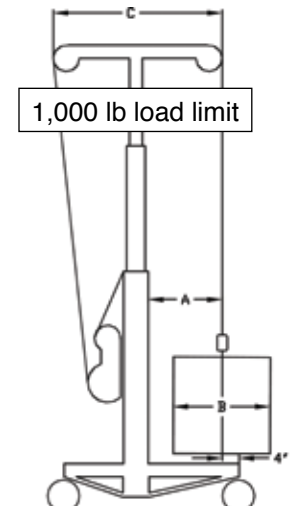

Part No.	Description	Weight		A		B		C	
		lbs	kg	inch	cm	inch	cm	inch	cm
781060	R-100/150 Tee-Head Extension Bar	21	9.5	22	55	43	108	48	120
781061	R-180 Tee-Head Extension Bar	24	11.0	29	73	58	145	63	158
781062	R-250 Tee-Head Extension Bar	33	15.0	37	93	73	183	68	173

Caution: Load center is moved to only 4" back of front casters, decreasing stability. Use carefully and only on bulky loads up to 1,000 lb/455 kg.

# FAB-MATE™

**SUMNER**

The hoist for  
all fab shop  
needs!

- ✓ 1,000 lb capacity (450 kg), 7 ft (2.1 m) lifting capacity
- ✓ Moves loads vertically and horizontally at the same time
- ✓ Sumner-built single-speed winch offers infinite positioning for accurate fit-ups
- ✓ 8" casters (200 mm) and special base allows load to "get close to the work"
- ✓ Accessories make Fab-Mate extremely versatile
- ✓ Priced for all budgets

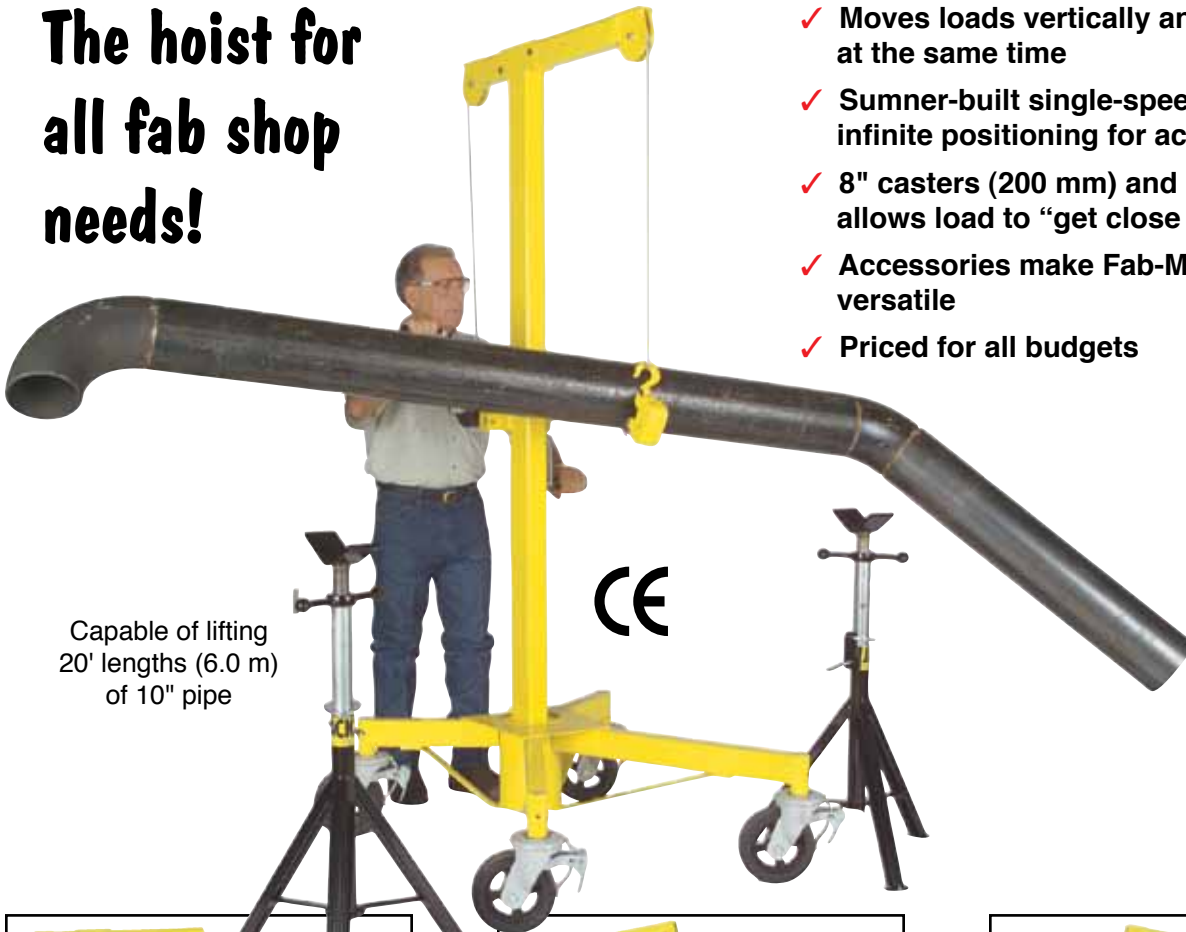

Capable of lifting  
20' lengths (6.0 m)  
of 10" pipe



Position fittings with  
Sumner Adjust-A-Fit  
(See Sumner Welding  
Make-Up Tools catalog)



Align flanges with  
Sumner Adjust-A-Flange  
(See Sumner Welding  
Make-Up Tools catalog)



Move plate with  
plate lifting clamp

Part No.	Description	Height		Width		Length		Weight	
		inch	cm	inch	cm	inch	cm	lbs	kg
783900	Fab-Mate	88-1/2	224	35	89	44	111	206	93

**SUMNER**

*Select from two  
Great Lifts!*

**SERIES 2000**  
**MATERIAL LIFT**

**SERIES 2100**  
**CONTRACTOR LIFT**



The Series 2000 is built for heavy material and continuous work. This compact lift offers strong mast design and a superior cabling system. The shorter mast sections allow the 2000 to fit through standard doorways without tipping. The compact design fits nicely into vehicles and requires little storage space.



Unmatched as a good all around contractor lift, the Series 2100 features a taller mast to reach desired work heights while requiring fewer mast sections. Hence, the 2100 is less expensive and lighter. The base, forks, winch, etc., are the same as the Series 2000.

# SERIES 2000 & 2100 LIFTS ARE LOADED WITH SAFETY AND OPERATIONAL FEATURES

# **SUMNER**

## Loading Bar

Great for overhead cranes

## Roller Wheels

Helps to roll into trucks or vans

## Inside-Mast Cable Feed

Cable feeds inside mast, removing exposed cable from near the operator's face.

## Pulley Guards

Load cable cannot come off.

## Sumner-built Winch

Highly reliable, single-speed winch uses idler roller to feed cable evenly on the drum to avoid cable flats. Handles are removable when not in use.

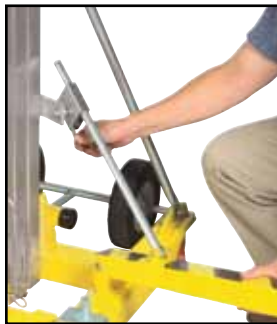

## Fast Action Stabilizer Legs

Mounted on base top, stabilizer legs fold down with ease and lock in place. The 2020, 2025, 2118 and 2124 models come with stabilizer legs standard (optional on models 2010, 2015, and 2112).



Standard Position

## 10" Rough Terrain Wheels

Makes loading a truck or van hassle free (optional on Series 2000 Lifts).

## Lockable 5" Casters

Hard tread urethane wheels with Delrin® bearings.



### Hold-Down Bar

Standard hold-down bar retains carriage assembly during transport. Hold-down bar is spring-loaded, retracts and stores behind mast when not in use.

**Part No. 783040**



### Reversible Forks

Forks easily remove by pulling plunger pins and can be reversed for added height or to get flush with ceiling.

**Available in optional galvanized finish!**

**Part No. 776270**



### Ideal for compact storage

No tools or loose hardware to worry about. Leg lock mechanism releases by pulling plunger pins and locks in the stored position. Leg rollers allow lift to be wheeled around. Forks also remove by pulling plunger pins.



## Series 2000

Part No.	Description	Max Height		Lifting Capacity		Lift Weight		Shipping Weight	
		Feet	Meter	lbs	kg	lbs	kg	lbs	kg
783700	2010 Material Lift	10' 5"	3.2	1,000	455.0	188	85.5	223	104.4
783701	2015 Material Lift	15' 2"	4.6	800	360.0	280	127.3	315	143.2
783702	2020 Material Lift	19' 11"	6.1	800	360.0	355	161.4	390	177.3
783703	2025 Material Lift	24' 8"	7.5	650	300.0	430	195.5	465	211.4

## Series 2100

783650	2112 Contractor Lift	13' 1"	4.0	650	300.0	252	114.5	287	130.5
783651	2118 Contractor Lift	18' 6"	5.6	650	300.0	321	145.9	356	161.8
783652	2124 Contractor Lift	23' 11"	7.3	650	300.0	366	166.0	399	181.4

# OPTIONAL FEATURES FOR SERIES 2000 & 2100 LIFTS



## Pipe Cradle (#783705)

Great for duct pipe or other HVAC applications. Slides over standard forks. Packaged in sets of two.



## Fork Extensions (#783691)

With the push of a button, forks may be extended from 28" to 42" (71–106 cm). With longer forks, the weight capacity decreases to 200 lbs (90 kg) and is clearly displayed on the forks when extended. A second button returns the extension for convenient storage inside the forks.

## Boom Carriage (#783642)

Ideal for installing pipe or lifting “from the top” applications. Uses four attaching plunger pins and has a 40" (100 cm) reach. Hook has five locations and load capacity decreases the farther out the boom is extended, from 650 lbs to 200 lbs (300 kg to 90 kg).

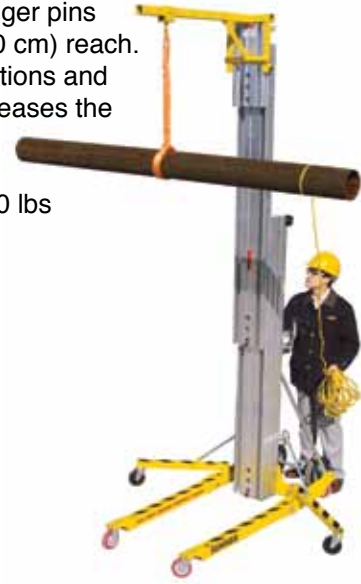

## Safety Brake

Each mast and carriage can have a factory installed, gravity actuated safety brake which holds loads in place in the event the cable should go slack.

Part No.	Description
783882	Safety brake - 2010 & 2112
783883	Safety brake - 2015 & 2118
783884	Safety brake - 2020 & 2124
783885	Safety brake - 2025



## Two Speed Winch Handle Kit (Factory Installed #783765)

The two speed winch handle offers a standard speed setting or a high speed setting for quickly positioning forks in half the time. Available only on Series 2100 lifts commencing with serial number 9433. For field installation kit, use part # 783761.

Series 2000 Material Lift Dimensions	2010		2015		2020		2025	
Height - stowed	76"	1.93 m	76"	1.93 m	76"	1.93 m	76"	1.93 m
Length - stowed	34"	0.86 m	34"	0.86 m	34"	0.86 m	34"	0.86 m
Height - operating	76"	1.93 m	76"	1.93 m	76"	1.93 m	76"	1.93 m
Length - operating	62"	1.57 m	62"	1.57 m	73"	1.84 m	73"	1.84 m
Base width	31-1/4"	0.80 m	31-1/4"	0.80 m	31-1/4"	0.80 m	31-1/4"	0.80 m
Width with stabilizer legs	74"	1.88 m	74"	1.88 m	74"	1.88 m	74"	1.88 m
Ground clearance	2-1/2"	6.4 cm	2-1/2"	6.4 cm	2-1/2"	6.4 cm	2-1/2"	6.4 cm
Load height (minimum)	6"	15.2 cm	6"	15.2 cm	6"	15.2 cm	6"	15.2 cm
Maximum height (forks down)	8' 7"	2.6 m	13' 4"	4.1 m	18' 1"	5.5 m	22' 10"	6.9 m
Maximum height (forks reversed)	10' 5"	3.2 m	15' 2"	4.6 m	19' 11"	6.1 m	24' 8"	7.5 m
Series 2100 Contractor Lift Dimensions	2112		2118		2124			
Height - stowed	84"	2.13 m	84"	2.13 m	84"	2.13 m		
Length - stowed	34"	0.86 m	34"	0.86 m	34"	0.86 m		
Height - operating	84"	2.13 m	84"	2.13 m	84"	2.13 m		
Length - operating	62"	1.57 m	73"	1.84 m	73"	1.84 m		
Base width	31-1/4"	0.80 m	31-1/4"	0.80 m	31-1/4"	0.80 m		
Width with stabilizer legs	74"	1.88 m	74"	1.88 m	74"	1.88 m		
Ground clearance	2-1/2"	6.4 cm	2-1/2"	6.4 cm	2-1/2"	6.4 cm		
Load height (minimum)	6"	15.2 cm	6"	15.2 cm	6"	15.2 cm		
Maximum height (forks down)	11' 1"	3.4 m	16' 6"	5.0 m	22' 1"	6.7 m		
Maximum height (forks reversed)	13' 1"	4.0 m	18' 6"	5.6 m	23' 11"	7.3 m		



# SERIES 2200 LIL' HOISTER LIFT



Lightweight...  
Transportable...

Ideal for many  
lifting tasks!

**2208 LIFT**



**2210 LIFT**



## Just of few of the applications for the Lil' Hoister:

- HVAC compressor Installation
- Loading and unloading equipment & material from service vehicles
- Cabinet installation
- Lifting electrical trays
- Positioning pipe & ducts
- Installing air conditioners
- Handling machine parts & tooling
- Loading equipment in rental yards
- Hoisting small beams
- Positioning hospital TVs
- Hauling & lifting cement bags
- Installing appliances
- Removing electrical motors
- Installing light fixtures

# SERIES 2200 LIFTS

# SUMNER

## Fold-out Roller Wheels

Great for rolling lift in and out of vans and trucks



## Convenient Handle (Model 2208)

Enables use as a hand truck



## Two Speed Winch Handle

The two speed option allows the operator to raise and lower loads at standard speed or at high speed (less than half the time of standard).

Strap feeds away from the operator — no more cable in the face.



Standard Speed Position



High Speed Position

**Mast Braces**  
For extra strength and support

**8" Non-marring wheels**



### 2208 Lift (Part Number 784308)



The handy, double-masted 2208 Lift has many applications including positioning hospital TVs, equipment installation and wall-mounting AC units.

Height max. (forks up)	9' 0"	274 cm
Height max. (forks down)	7' 11"	241 cm
Lift capacity	300 lbs	135 kg
Height stowed	57"	145 cm
Length stowed	13"	33 cm
Length operating	41"	104 cm
Width stowed	26"	66 cm
Width max	31"	79 cm
Winch cranks per ft/m	8	24
Basic weight	95 lbs	43.2 kg

### 2210 Lift (Part Number 784310)



The double-masted 2210 Lift offers the capability of lifting light fixtures or AC units in low ceiling buildings. Its forks fit between most acoustical ceiling tiles.

Height max. (forks up)	11' 0"	335 cm
Height max. (forks down)	9' 11"	302 cm
Lift capacity	300 lbs	135 kg
Height stowed	70"	178 cm
Length stowed	13"	33 cm
Length operating	41"	104 cm
Width stowed	26"	66 cm
Width max	31"	79 cm
Winch cranks per ft/m	8	24
Basic weight	106 lbs	48 kg

### 1" Nylon Strap

—no more cable kinks.

### Dual I-beam Mast Design

Compact, light weight but strong.



### Reversible Forks

Two plunger pins permit quick release of forks. Forks may be removed for storage or reversed for added height.

### Mast Hold Down

Heavy duty spring clamps fasten the strap to the side of the fork assembly.

### Double Row Casters

Two 2" (5 cm) casters permit easy handling of heavy loads.

### Reversing Handle

For convenient, out of the way storage.

### Compact Storage

Remove forks and reposition legs for space saving storage.



### Legs Extend for Greater Stability

Plunger pin action allows quick adjustment.

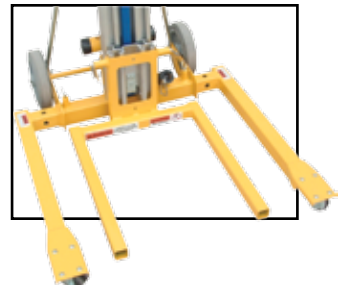

## Optional features available for Series 2200 Lifts

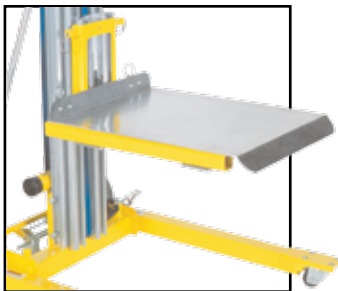

### Aluminum Tray (part no. 784240)

Lightweight and rust free, this aluminum tray slides on to forks and attaches quickly and safely with spring loaded plunger pins.



### Wheel Brake Kit (part no. 784218)

Easy to assemble brake kit for 8" (20 cm) wheels prevents lift from moving while being loaded. Recommended for use with the aluminum tray.



### Dually Wheel Kit (part no. 784258)

Ideal for use on grass or dirt or when the lift is used as a hand truck.

# SERIES 2300

## DRYWALL/HVAC LIFT

**SUMNER**



**One Man Operation!**

- ✓ Solid, safe construction (CE)
- ✓ Two speed winch handle
- ✓ Quick, tool-free assembly
- ✓ One person operation
- ✓ Tilts 65° for drywall installation
- ✓ Lifts loads of 150 lbs (70 kg) up to 11' 6" (3.5 m) or 15 ft (4.5 m)
- ✓ Lightweight



**Check the features...**

Self-braking winch with two speed winch handle. No spinning wheels, no free fall, no pinched fingers!



lo speed



hi speed



stored position



Convenient carrying handle

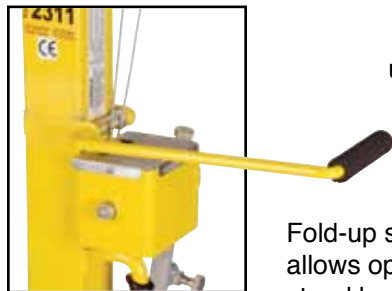

Fold-up steering lever allows operator to stand back and guide load to exact location.

Back stop brake prevents lift from backing up while unloading drywall panels



# SUMNER



Cradle arm can be set in multiple positions (up to 65 degrees) using plunger pins or cradle can be allowed to float freely.



Cradle outriggers pull out to accommodate large drywall panels.

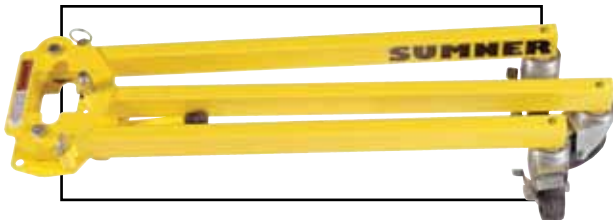

Base legs fold up to compact package for storage.



Fits in a car trunk!

## More Series 2300 features...



**A  
Versatile  
Jobsite  
Lift!**



Cradle arms mount quickly on cradle using fast-action plunger pins.

## 2311 & 2315 LIFTS - Perfect for Drywall Installation



Base legs adjust for travel through standard doorways — with or without load.



Steering lever provides optimum positioning.



Cradle tilts up to 45° for cathedral ceilings.



## DRYWALL LIFT TRUCK

Part No. 784510

Mast, base and cradle fit neatly and securely on the truck. The 10" wheels are ideal for job site terrain or going up or down stairs.



### Drywall Cradle Assembly part no. 784355

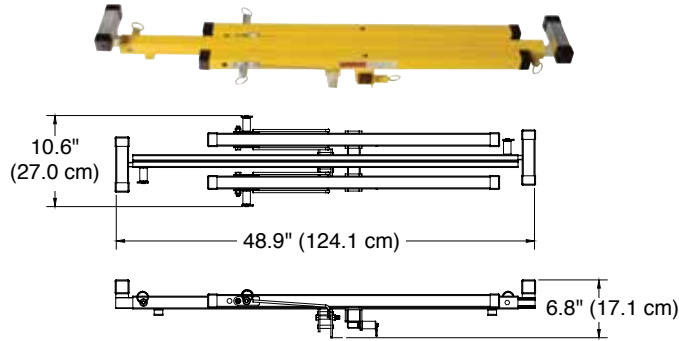

### HVAC/Light Cradle (optional) part no. 784474

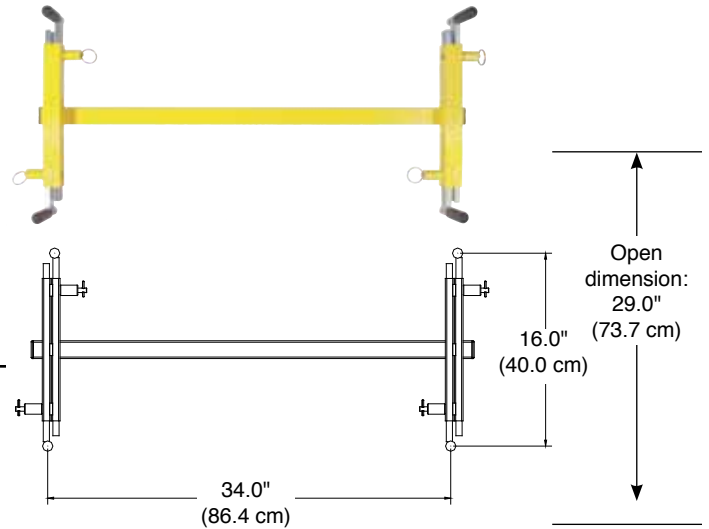

### Base Assembly part no. 784420

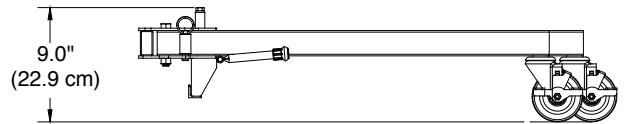
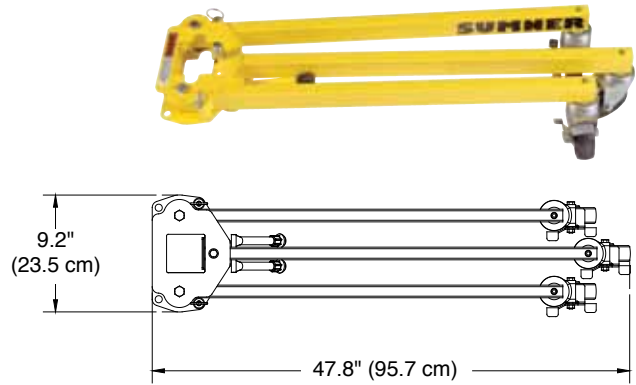

### Mast Assembly



#### 2311 (part no. 784347)

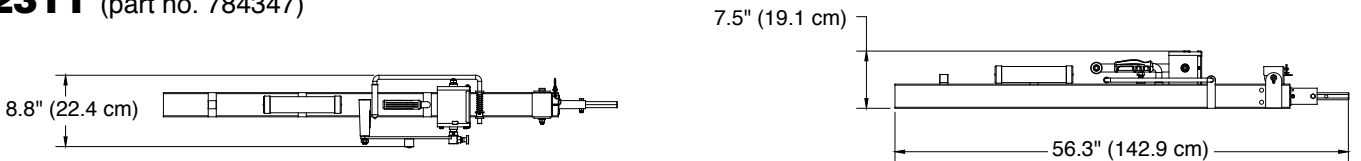

#### 2315 (part no. 784352)

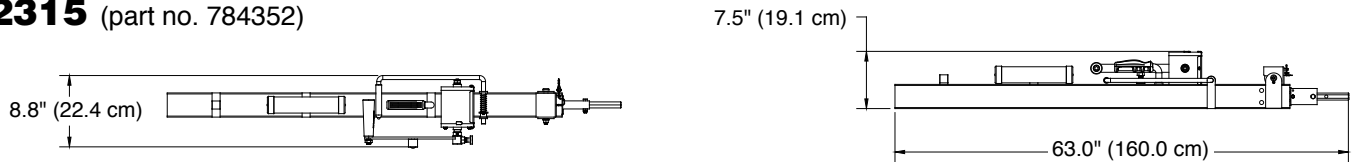

Part No.	Description	Load Height (maximum)		Load Height (minimum)		Load Capacity		Max. Drywall Dimensions		Base Height	Base Footprint (open)		Lift Weight		
		Feet	Meter	Inch	cm	Lb	Kg	Feet	Meter	Inch	cm	Inches	meters	lbs	kg
784345	2311 Drywall Lift	11' 6"	3.5	34"	86	150	70	4 x 12	1.2 x 3.7	7"	18	55 x 55 x 52	1.4 x 1.4 x 1.3	98	44.6
784346	2315 Drywall Lift	15'	4.5	48"	122	150	70	4 x 12	1.2 x 3.7	7"	18	55 x 55 x 52	1.4 x 1.4 x 1.3	104	47.3
784332	2315 HVAC Lift								N/A					87	39.5
784340	2311 Standard Model with single cable, mast and base only, no cradle.														
784342	2315 Standard Model with single cable, mast and base only, no cradle.														

# EL-405 **SUMNER** STACKER LIFT



**Large Lifting Tray**  
24" x 28"  
(61 x 71 cm)

- ✓ 400 lbs (180 kg) lift capacity
- ✓ 53" (135 cm) lifting height
- ✓ Two-speed winch handle
- ✓ Quick action wheel brake
- ✓ Large lifting surface

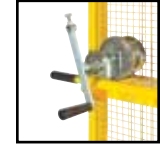
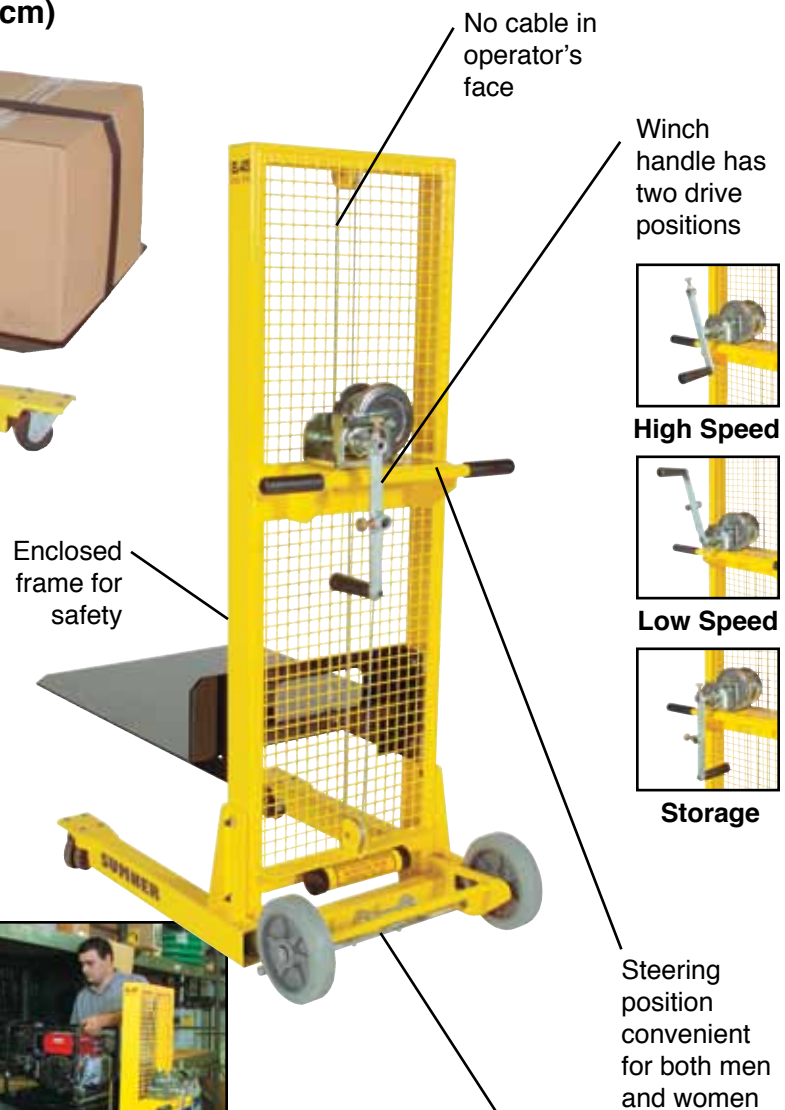

**High Speed**

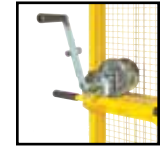

**Low Speed**

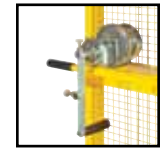

**Storage**

Shelf overlap feature for ease of loading



Tray ideal for lifting large boxes, generators, pumps, tooling, etc.







**Ideal, adjustable work platform for repair shops.**



**Great for loading customer vehicles.**



Quick action retention strap holds load on lift tray. Strap features retractor to house loose strap. Strap has a seat belt style push button release and a ratchet tightening mechanism.

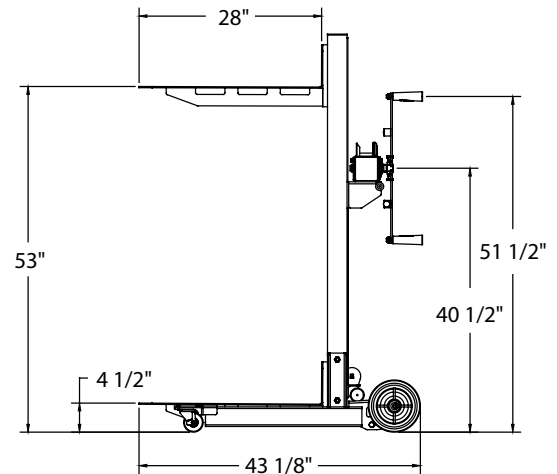
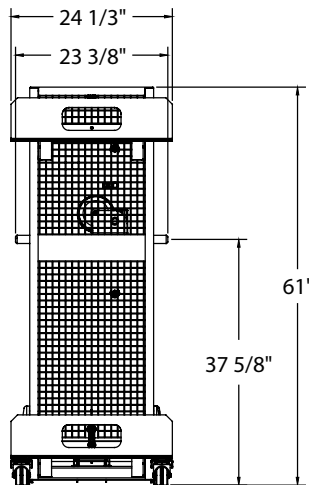

Part No.	Description	Max Height		Lifting Capacity		Lift Weight		Shipping Weight	
		Feet	Meter	lbs	kg	lbs	kg	lbs	kg
784650	EL-405 Stacker Lift	4' 5"	1.35	400	180	170	78	182	83

### EL 405 Extension Strap Kit (Part no. 784685)

An additional seat belt type strap may be attached to the bottom of the tray to provide securing of bulky cargo. With the combination of the ratchet strap and extension strap, a total 8' 6" (2.5 m) is available for cargo hold down.



# SUMNER

## SERIES 2412 CONTRACTOR LIFT



### The perfect lift for:

- HVAC contractors
- Electrical contractors
- Industrial maintenance
- Steel erectors
- Facility management

- ✓ A super compact 12 ft (3.6 m) lift
- ✓ 400 lbs (180 kg) lift capacity
- ✓ One piece construction –no loose pieces
- ✓ Easily portable for one person operation
- ✓ Fits most SUVs and vans
- ✓ 13 ft. height when forks reversed

### Ideal for Compact Storage

No tools or loose hardware to worry about. Leg lock mechanism releases with plunger pin and slides on base leg.



### Compact Storage

Forks remove and legs reposition for space saving storage.



Leg roller allows unit to wheel in stored position.

## The SERIES 2412 LIFT

...Check the features!



Fits in most vans



### Handle

Use convenient handle for "hand truck" mobility and to position lift at point of use.

### Winch

Coffee grinder style winch features auto-braking and detachable winch handles.

### Roller Wheels

Handy wheels located to ease rolling into vehicles for transportation.

**8" (20 cm) non-marring wheels**

### Pulley Guards

Contains load cable ... line cannot come off.



### Reversible Forks

Two plunger pins permit quick release of forks. Forks may be removed for storage or reversed for added height.

### Inside-Mast Cable Feed

Cable feeds inside mast, removed from the operator for safety – similar to the 2000 and 2100 Series lifts.

### Double Row Casters

- ✓ Four 3" (7.5 cm) casters permit easy handling of heavy loads
- ✓ Swivel independently
- ✓ Lockable to insure safety
- ✓ Allow for multi-directional positioning of lift

<b>2412 Lift (Part Number 784750)</b>		
Height max. (forks up)	13'	3.9 m
Height max. (forks down)	12'	3.6 m
Lift capacity	400 lbs	180 kg
Height stowed	62-3/4"	159.4 cm
Length stowed	23"	58.4 cm
Length operating	48"	121.9 cm
Width stowed	26-3/8"	67.1 cm
Width max	26-3/8"	67.1 cm
Winch cranks per ft/m	8	24
Basic weight	195 lbs	88.5 kg

### Optional Fork Extensions

Forks may be extended from 23-1/4" (59.2 cm) to 29-7/16" (75.7 cm).



## Optional features available for the Series 2412 Lift

### Cable Brake (Part no. 784755)

Each mast and carriage can have a factory installed, gravity actuated safety brake which holds loads in place in the event cable goes slack.

### Fork Extension (Part no. 784695)

With the push of a button, forks may be extended from 23-1/4" (59.2 cm) to 29-7/16" (75.7 cm). When using the fork extensions the weight capacity reduces to 200 lbs (90 kg), as is clearly marked on the extended forks. A second button returns the extension for storage inside forks.



### Tray (Part no. 784320)

24" x 48"  
(61 x 71 cm)  
steel tray  
slides  
onto forks.

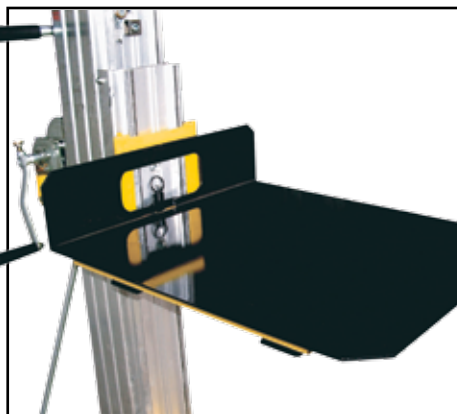

### Pipe Cradle (Part no. 783705)

Great for  
air ducts or  
other HVAC  
applications.  
Slides over  
forks. Packaged  
two per set.

